



US008987043B2

(12) **United States Patent**  
**Park et al.**

(10) **Patent No.:** **US 8,987,043 B2**  
(45) **Date of Patent:** **Mar. 24, 2015**

(54) **ORGANIC LIGHT EMITTING DIODE  
DISPLAY AND METHOD FOR  
MANUFACTURING ORGANIC LIGHT  
EMITTING DIODE DISPLAY**

USPC ..... 257/29, 40, 88; 438/99, 127; 216/24;  
313/46, 504  
See application file for complete search history.

(75) Inventors: **Yong-Hwan Park**, Yongin (KR);  
**Sang-Joon Seo**, Yongin (KR); **Jae-Seob  
Lee**, Yongin (KR); **Seung-Hun Kim**,  
Yongin (KR); **Jin-Kwang Kim**, Yongin  
(KR)

(56) **References Cited**

U.S. PATENT DOCUMENTS

6,803,245 B2\* 10/2004 Auch et al. .... 438/26  
6,872,114 B2\* 3/2005 Chung et al. .... 445/24  
8,309,379 B2\* 11/2012 Park et al. .... 438/34  
2011/0134018 A1 6/2011 Seo et al.

(73) Assignee: **Samsung Display Co., Ltd.** (KR)

FOREIGN PATENT DOCUMENTS

(\* ) Notice: Subject to any disclaimer, the term of this  
patent is extended or adjusted under 35  
U.S.C. 154(b) by 15 days.

KR 1020040053495 6/2004  
KR 1020070047114 5/2007  
KR 1020080013068 2/2008

(21) Appl. No.: **13/300,176**

\* cited by examiner

(22) Filed: **Nov. 18, 2011**

*Primary Examiner* — Matthew W Such

(65) **Prior Publication Data**

*Assistant Examiner* — Warren H Kilpatrick

US 2012/0305981 A1 Dec. 6, 2012

(74) *Attorney, Agent, or Firm* — Knobbe Martens Olson &  
Bear LLP

(30) **Foreign Application Priority Data**

(57) **ABSTRACT**

Jun. 1, 2011 (KR) ..... 10-2011-0052904

A method of manufacturing an OLED display includes: form-  
ing an organic light emitting element on a first substrate;  
forming, on the organic light emitting element, a thin film  
encapsulation layer that seals the organic light emitting ele-  
ment with the first substrate; providing a second substrate;  
forming a flexible protection layer on the second substrate;  
attaching the first substrate and the second substrate to each  
other; and separating the second substrate from the flexible  
protection layer.

(51) **Int. Cl.**  
**H01L 51/52** (2006.01)

(52) **U.S. Cl.**  
CPC ..... **H01L 51/5253** (2013.01); **H01L 51/5246**  
(2013.01); **H01L 2227/326** (2013.01); **H01L**  
**2251/5338** (2013.01)

USPC ..... **438/99**; **257/E51.02**

(58) **Field of Classification Search**  
CPC ..... H01L 51/5246; H01L 51/5253

**6 Claims, 12 Drawing Sheets**

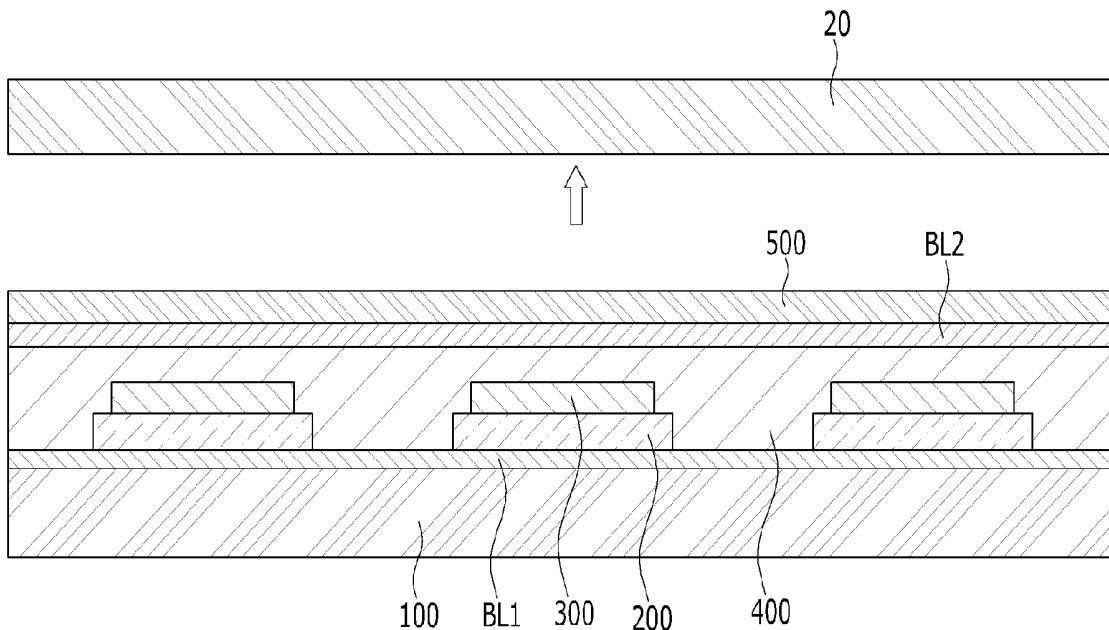

FIG. 1

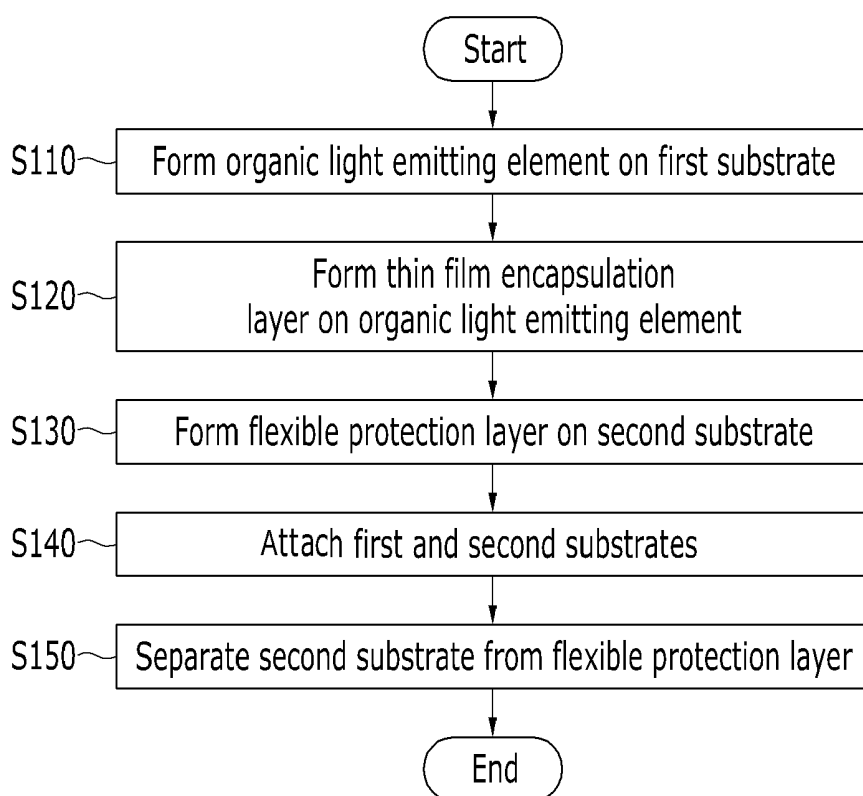

FIG. 2

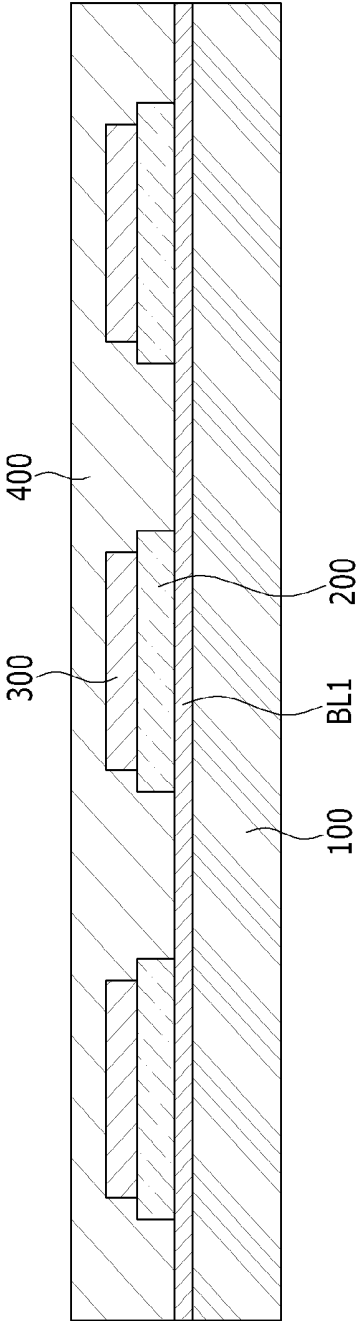

FIG. 3

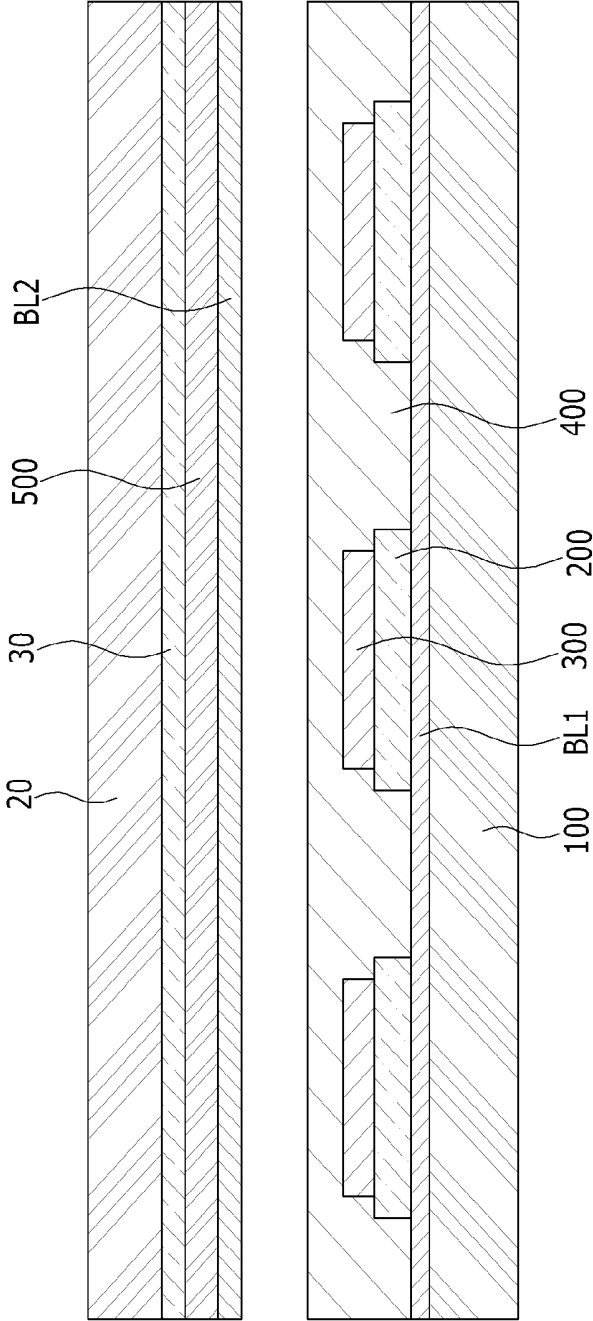

FIG. 4

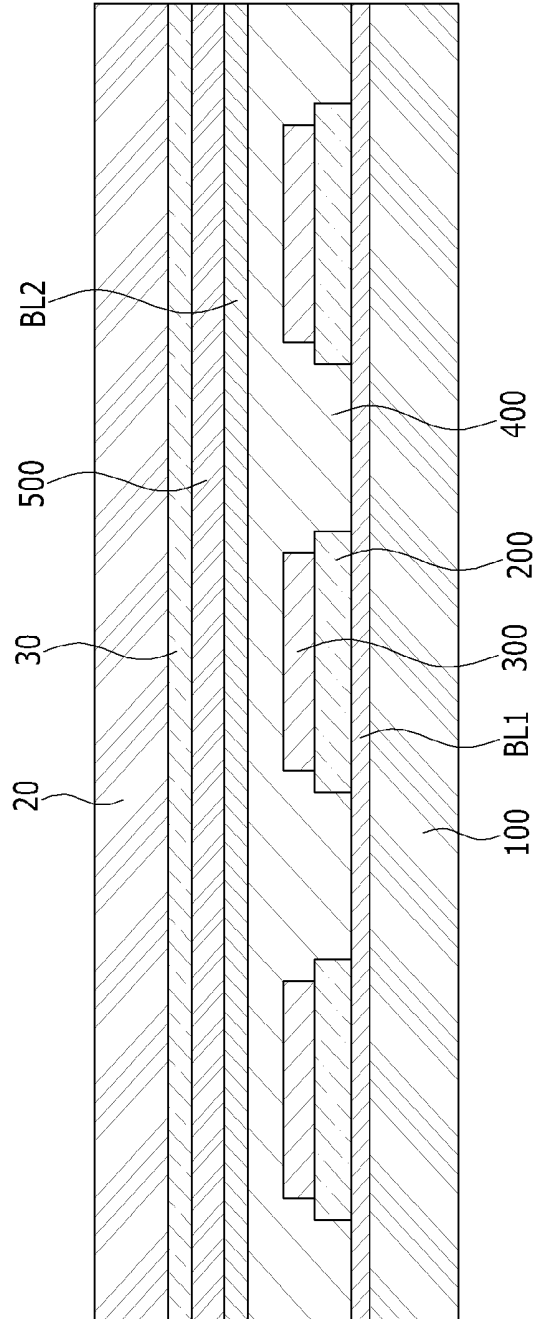

FIG. 5

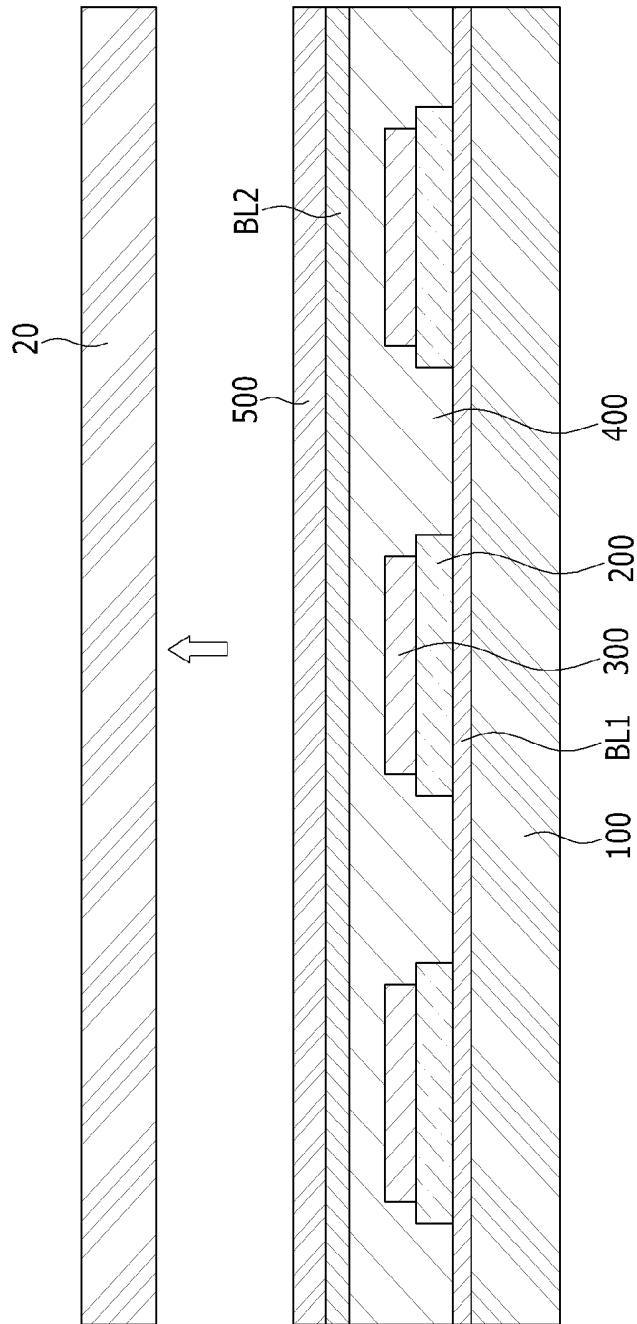

FIG. 6

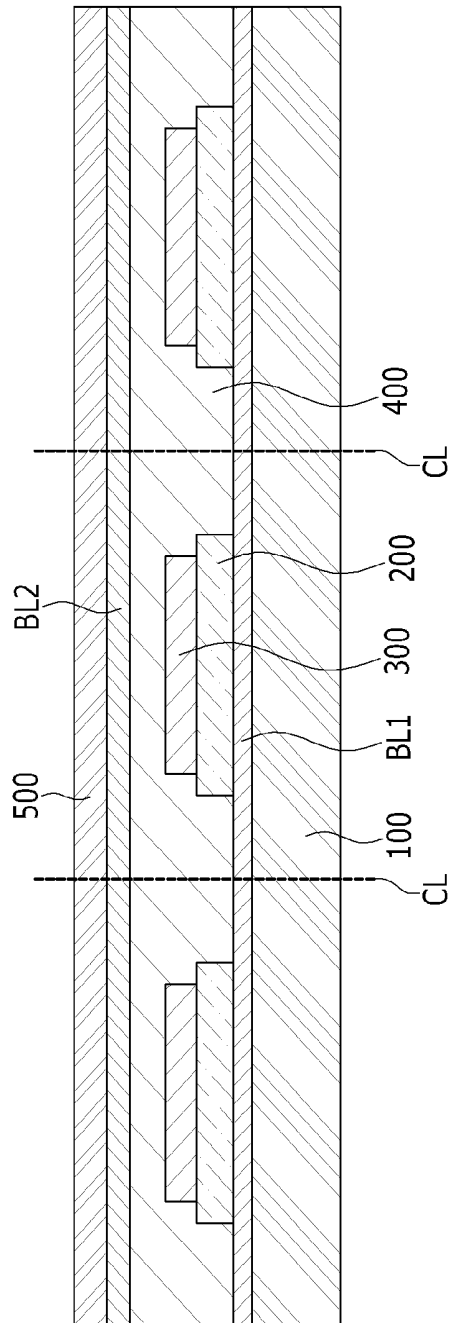

FIG. 7

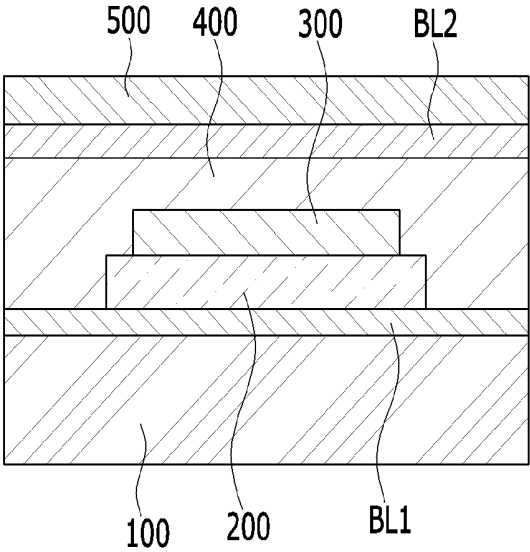





FIG. 10

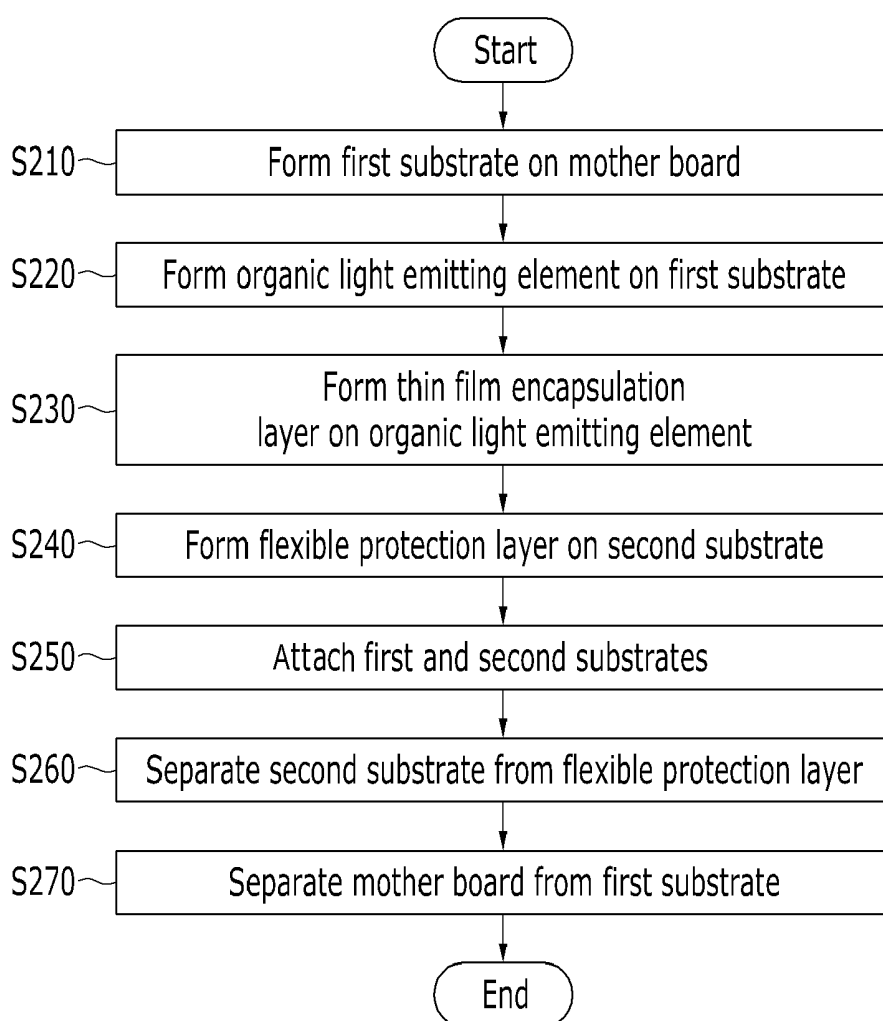

FIG. 11

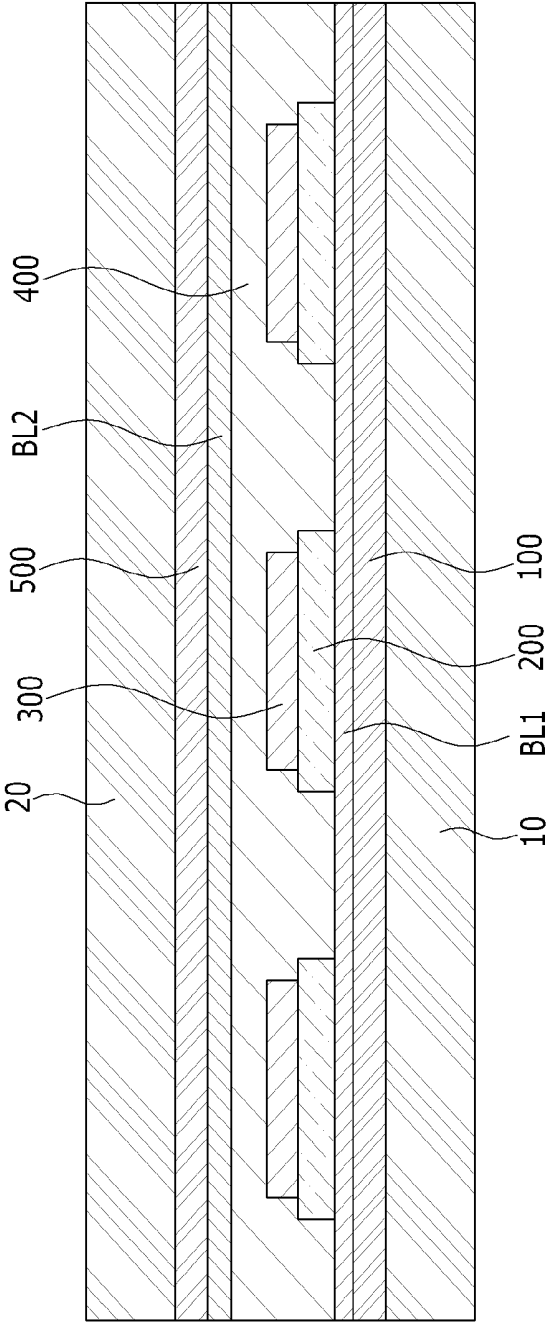
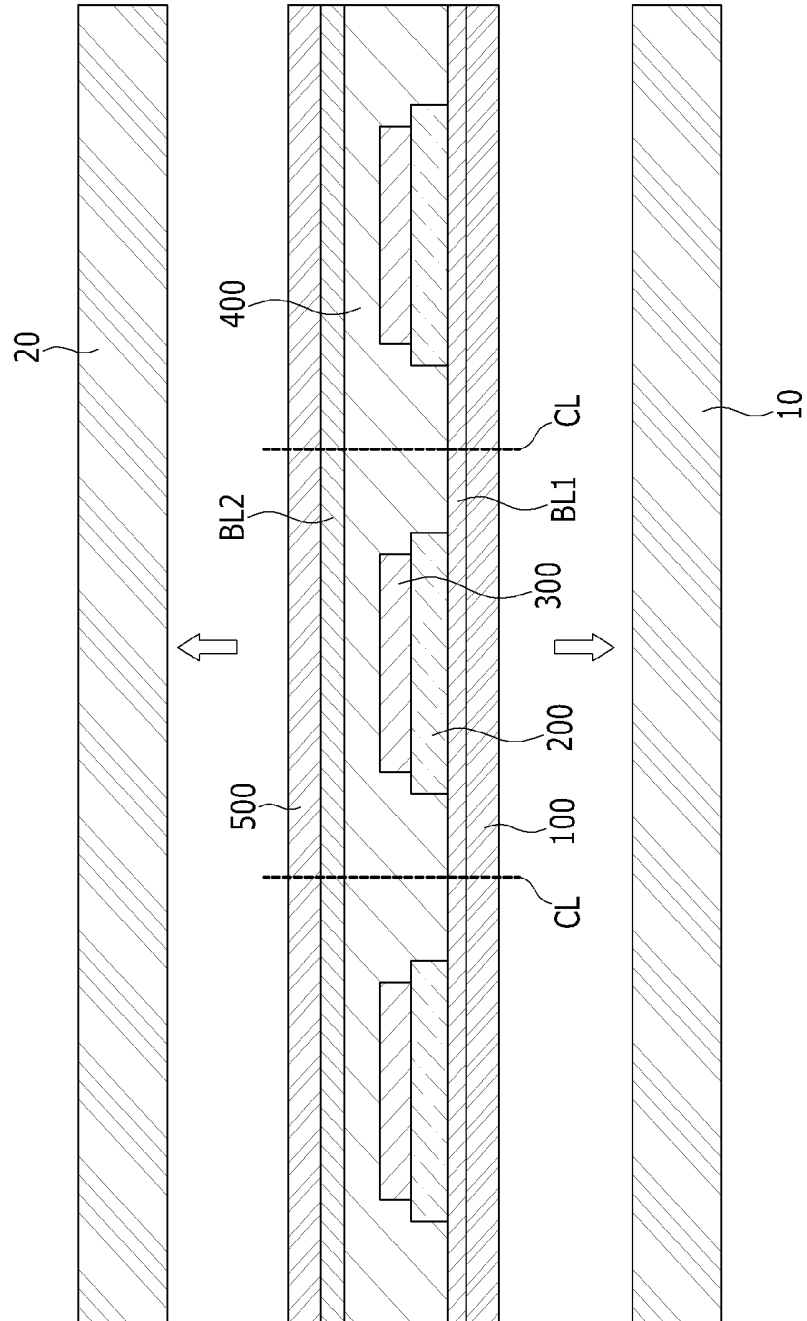

FIG. 12



1

**ORGANIC LIGHT EMITTING DIODE  
DISPLAY AND METHOD FOR  
MANUFACTURING ORGANIC LIGHT  
EMITTING DIODE DISPLAY**

**CROSS-REFERENCE TO RELATED  
APPLICATIONS**

This application claims priority to and the benefit of Korean Patent Application No. 10-2011-0052904 filed in the Korean Intellectual Property Office on Jun. 1, 2011, the entire contents of which are incorporated herein by reference.

**BACKGROUND**

**1. Field**

The described technology relates generally to an organic light emitting diode (OLED) display, and a manufacturing method of an OLED display. More particularly, the described technology relates to an OLED display including a thin film encapsulation layer as an encapsulation member and a manufacturing method of an OLED display.

**2. Description of Related Technology**

Display devices display images, and recently, organic light emitting diode (OLED) displays have been in the spotlight.

An organic light emitting diode (OLED) generally display has a self-emitting characteristic and does not need a separate light source, such that the thickness and weight thereof are decreased, compared to a liquid crystal display. The organic light emitting diode (OLED) display typically has high-grade characteristics such as low power consumption, high luminance, high reaction speed, and the like.

In general, the OLED display includes a substrate, an organic light emitting diode disposed on the substrate and displaying an image, and an encapsulation member facing the substrate while interposing the organic light emitting diode therebetween to encapsulate the organic light emitting diode.

Recently, a flexible OLED display using a thin film encapsulation layer as an encapsulation member has been developed.

However, a conventional flexible OLED display needs to attach a flexible protection layer such as a polymer film to a thin film encapsulation layer to protect the thin film encapsulation layer from external interference. The protection layer cannot be easily attached to the thin film encapsulation layer due to movement of the flexible protection layer. Particularly, when the OLED display is large in size, the flexible protection layer is also large-sized, and accordingly attaching the protection layer to the thin film encapsulation layer becomes more difficult.

The above information disclosed in this Background section is only for enhancement of understanding of the background of the described technology and therefore it may contain information that does not form the prior art that is already known in this country to a person of ordinary skill in the art.

**SUMMARY OF CERTAIN INVENTIVE ASPECTS**

One embodiment provides a manufacturing method of an OLED display that can easily handle a flexible protection layer.

Another embodiment provides an OLED display of which a flexible protection layer is easily attached to a thin film encapsulation layer.

One aspect provides a manufacturing method of an OLED display, including: forming an organic light emitting element

2

on a first substrate; forming, on the organic light emitting element, a thin film encapsulation layer that seals the organic light emitting element with the first substrate; providing a second substrate; forming a flexible protection layer on the second substrate; attaching the first substrate and the second substrate to each other; and separating the second substrate from the flexible protection layer.

The flexible protection layer may include resin.

Forming the flexible protection layer on the second substrate may include forming a sacrificial layer between the second substrate and the flexible protection layer, and separating the second substrate from the flexible protection layer may include removing the sacrificial layer.

The manufacturing method of the OLED display further includes forming the first substrate on a mother board and separating the mother board from the first substrate, and the first substrate may include flexible resin.

The thin film encapsulation layer may include only a single-layered inorganic layer.

A second aspect of the present invention provides an OLED display manufactured by the manufacturing method of the OLED display.

The flexible protection layer may have a thickness in a range between about 1  $\mu\text{m}$  to about 100  $\mu\text{m}$ .

According to one embodiment, a manufacturing method of an OLED display that can easily handle a flexible protection layer is provided.

In addition, an OLED display of which a flexible protection layer is easily attached to a thin film encapsulation layer is provided.

**BRIEF DESCRIPTION OF THE DRAWINGS**

FIG. 1 is a flowchart of one embodiment of a manufacturing method of an organic light emitting diode (OLED) display.

FIG. 2 to FIG. 6 illustrate an embodiment of the manufacturing method of the OLED display.

FIG. 7 is a cross-sectional view of an embodiment of an OLED display.

FIG. 8 is a layout view of a pixel structure of the embodiment of an OLED display shown in FIG. 7.

FIG. 9 is a cross-sectional view of FIG. 8, taken along the line IX-IX.

FIG. 10 is a flowchart of another embodiment of a manufacturing method of an OLED display.

FIG. 11 and FIG. 12 illustrate another embodiment of the manufacturing method of the OLED display.

**DETAILED DESCRIPTION OF CERTAIN  
INVENTIVE EMBODIMENTS**

In the following detailed description, certain embodiments are shown and described, simply by way of illustration. As those skilled in the art would realize, the described embodiments may be modified in various ways, without departing from the spirit or scope of the present invention.

Accordingly, the drawings and description are to be regarded as illustrative in nature and not restrictive. Like reference numerals generally designate like elements throughout the specification.

In addition, the size and thickness of each component shown in the drawings are arbitrarily shown for understanding and ease of description, but the present invention is not limited thereto.

In the drawings, the thickness of layers, films, panels, regions, etc., may be exaggerated for clarity. In the drawings,

for understanding and ease of description, the thicknesses of some layers and areas may be exaggerated. It will be understood that when an element such as a layer, film, region, or substrate is referred to as being “on” another element, it can be directly on the other element or intervening elements may also be present.

In addition, unless explicitly described to the contrary, the word “comprise” and variations such as “comprises” or “comprising”, will be understood to imply the inclusion of stated elements but not the exclusion of any other elements. Further, throughout the specification, “on” implies being positioned above or below a target element and does not imply being necessarily positioned on the top on the basis of a gravity direction.

Hereinafter, one embodiment of a manufacturing method of an organic light emitting diode (OLED) display will be described with reference to FIG. 1 to FIG. 6.

FIG. 1 is a flowchart of an embodiment of a manufacturing method of an OLED display. FIG. 2 to FIG. 6 illustrate an embodiment of the manufacturing method of the OLED display.

As shown in FIG. 1 and FIG. 2, an organic light emitting element 300 is formed on a first substrate 100 (S110).

A plurality of wire portions 200 arranged at a distance from each other, and a plurality of organic light emitting elements 300 arranged at a distance from each other are formed on the first substrate 100. The first substrate 100 is made from a material including at least one of an inorganic material such as glass, resin, or metal. The material may be light-reflective, light-transmissive, light-absorptive, or light-transflective. A first barrier layer BL 1, including at least one of an organic layer and an inorganic layer, is disposed between the first substrate 100 and the wire portions 200. Each wire portion 200 and each organic light emitting element 300 will be described in further detail in the description of another embodiment of an OLED display.

A thin film encapsulation layer 400 is formed on the organic light emitting element 300 (S120).

The thin film encapsulation layer 400 is formed on the organic light emitting element 300 to seal the plurality of organic light emitting elements 300 together with the first substrate 100. The thin film encapsulation layer 400 includes an inorganic layer. The inorganic layer may be a single layer or a multi-layer including at least one of an aluminum oxide such as silicon oxide (SiOx), silicon nitride (SiNx), titanium oxide (TiOx), and alumina (Al<sub>2</sub>O<sub>3</sub>) and silicon oxynitride (SiON).

In some embodiments, the thin film encapsulation layer 400 includes a single-layered inorganic layer. In other embodiments, the thin film encapsulation layer 400 may be formed by alternately layering at least one organic layer and at least one inorganic layer. The organic layer may be a single or multi layer including a resin such as polyethylene terephthalate (PET), polyimide (PI), and polycarbonate (PC), or may be a single or multi layer including engineering plastic including at least one of glass fiber reinforced plastic (FRP), polyethyleneterephthalate (PET), and polymethylmethacrylate (PMMA). The inorganic layer may be a single or multi layer including at least one of aluminum oxide such as silicon oxide (SiOx), silicon nitride (SiNx), titanium oxide (TiOx), and alumina (Al<sub>2</sub>O<sub>3</sub>) and silicon oxynitride.

In some embodiments, the following process is performed after the thin film encapsulation layer 400 is formed on the organic light emitting element 300. In other embodiments, the following process may be performed after the organic

light emitting element 300 performed. In such embodiments, forming of the thin film encapsulation layer 400 may be omitted.

As shown in FIG. 3, a flexible protection layer 500 is formed on the second substrate 20 (S130).

The second substrate 20 may be rigid and include at least one of an inorganic material such as glass, resin, or metal. A sacrificial layer 30, a flexible protection layer 500, and a second barrier layer BL2 having at least one of an organic layer and an inorganic layer are sequentially formed on the second substrate. The sacrificial layer 30 may be an insulating layer including at least one of metal, an amorphous material, silicon oxide, silicon nitride, and a metal oxide. The flexible protection layer 500 includes a resin and has a thickness between about 1 μm to about 100 μm. In some embodiments, the flexible protection layer 500 may be a polymer film. Since the flexible protection layer 500 has the above-stated thickness and flexible characteristic, it may be moved due to external interference or stress, but the flexible protection layer 500 remains fixed by the second substrate 20 because it is formed on the rigid second substrate 20.

As shown in FIG. 4, the first substrate 100 and the second substrate 20 are sealed to each other (S140).

The first substrate 100 and the second substrate 20 are sealed to each other such that the flexible protection layer 500 and the thin film encapsulation layer 400 are arranged opposite to each other. The attaching between the first substrate 100 and the second substrate 20 may be performed by forming an adhesive layer on at least one of a surface of the thin film encapsulation layer 400 and a surface of the second barrier layer BL2.

The flexible protection layer 500 is attached on the thin film encapsulation layer 400 together with the second substrate 20. The flexible protection layer 500 is rigidly fixed to the second substrate 20. Accordingly, the flexible protection layer 500 can be easily attached to the thin film encapsulation layer 400 without having a difficulty in handling of the flexible protection layer 500 due to movement of the flexible protection layer 50. Although the first substrate 100 is large-sized, the flexible protection layer 500 that is large in size corresponding to the first substrate 100 is attached to the thin film encapsulation layer 400 in the state of being rigidly fixed by the second substrate 20, and therefore the flexible protection layer 500 can be easily attached to the thin film encapsulation layer 400. Further, although the thickness of the flexible protection layer 500 is less than about 1 μm, the flexible protection layer 500 is attached to the thin film encapsulation layer 400 while being rigidly fixed by the second substrate 20 so that the flexible protection layer 500 can be easily attached to the thin film encapsulation layer 400. The flexible protection layer 500 is attached to the thin film encapsulation layer 400 by fixing the same to the second substrate 20 so that the flexible protection layer 500 can be easily attached to the thin film encapsulation layer 400 without considering movement of the flexible protection layer 500. The flexible protection layer 500 may be an optical film of a polarizing or phase difference film.

As shown in FIG. 5, the second substrate 20 is separated from the flexible protection layer 500 (S150).

The second substrate 20 is separated from the flexible protection layer 500 by removing the sacrificial layer 30 using a lift-off or wet-etching process. The separated second substrate 20 may be recycled in the next process.

As shown in FIG. 6, another embodiment of an OLED display (to be described below) is manufactured by cutting the first substrate 100, the first barrier layer BL1, the thin film encapsulation layer 400, the second barrier layer BL2, and the

flexible protection layer **500** along an imaginary cutting line CL disposed between neighboring organic light emitting elements **300** among the plurality of organic light emitting elements **300** using a cutting means such as laser or a diamond cutter.

As described, according to an embodiment of the manufacturing method of the OLED display, the flexible protection layer **500** is attached to the thin film encapsulation layer **400** together with the second substrate **20** while being rigidly fixed by the second substrate **20** so that the flexible protection layer **500** can be easily attached to the thin film encapsulation layer **400** without having a difficulty in handling of the flexible protection layer **500** due to movement of the flexible protection layer **500**. As described, as the flexible protection layer **500** attached to the thin film encapsulation layer **400** can be easily handled by using an embodiment of the manufacturing method of the OLED display, an OLED display large in size and slim in thickness can be easily manufactured by setting the thickness of the flexible protection layer **500** to, for example, about 1  $\mu\text{m}$ .

Hereinafter, another embodiment of an OLED display will be described with reference to FIG. 7 to FIG. 9. Another embodiment of the OLED display may be manufactured by the manufacturing method of the OLED display according to the above-described embodiment.

FIG. 7 is a cross-sectional view of another embodiment of an OLED display.

As shown in FIG. 7, an embodiment of the OLED display includes a first substrate **100**, a first barrier layer BL1, a wire portion **200**, an organic light emitting element **300**, a thin film encapsulation layer **400**, a second barrier layer BL2, and a flexible protection layer **500**.

The first substrate **100** may be flexible, making the entire OLED display flexible. The thin film encapsulation layer **400** may be formed as a thin film, and the flexible protection layer **500** may be slim.

The wire portion **200** includes first and second thin film transistors **11** and **21** (shown in FIG. 8), and drives the organic light emitting element **300** by transmitting a signal thereto. The organic light emitting element **300** displays an image by emitting light according to the signal transmitted from the wire portion **200**.

The organic light emitting element **300** is disposed on the wire portion **200**.

Hereinafter, an internal structure of another embodiment of the OLED display will be described with reference to FIG. 8 and FIG. 9.

FIG. 8 is a layout view of a pixel structure of an embodiment of the OLED display. FIG. 9 is a cross-sectional view of FIG. 8, taken along the line IX-IX.

The detailed structure of one embodiment of the wire portion **200** and the organic light emitting element **300** are shown in FIG. 8 and FIG. 9, but other embodiments are also possible. The structure of the wire portion **200** and the organic light emitting element **300** may be variously modified within a range that can be realized by a person skilled in the art. For example, in the accompanying drawing, an active matrix (AM) organic light emitting diode display having a 2Tr-1Cap structure that includes two thin film transistors (TFTs) and one capacitor in one pixel is shown as an OLED display. In other embodiments, the number of thin film transistors, the number of capacitors, and the number of wires of the OLED display may differ. The pixel represents a minimum unit displaying an image, and the OLED displays an image using a plurality of pixels.

As shown in FIG. 8 and FIG. 9, an embodiment of the OLED display includes a switching thin film transistor **11**, a

driving thin film transistor **21**, a capacitor **80**, and an organic light emitting element **300** which are formed in each pixel. The switching thin film transistor **11**, the thin film transistor **21**, and the capacitor **80** are collectively referred to as a wire portion **200**. The wire portion **200** further includes a gate line **151**, a data line **171**, and a common power line **172**. The gate lines **151** are arranged in one direction, and the common power lines **172** cross the gate lines **151** and the data lines **171** in an insulated manner. In some embodiments, one pixel may be defined as the boundary of the gate line **151**, the data line **171**, and the common power line **172**.

The organic light emitting element **300** includes a first electrode **710**, an organic emission layer **720** formed on the first electrode **710**, and a second electrode **730** formed on the organic emission layer **720**. In some embodiments, the first electrode **710** may be an anode, which is a hole injection electrode, and the second electrode **730** may be a cathode, which is an electron injection electrode. In other embodiments, the first electrode **710** may be a cathode and the second electrode **730** may be an anode. Holes and electrons are injected into the organic emission layer **720** respectively from the anode **710** and the cathode **730**. When an exciton, in which a hole and an electron injected into the organic emission layer **720** are coupled to each other, falls from an excited state to a ground state, light emission occurs. At least one of the first electrode **710** and the second electrode **730** may have a light transmissive structure, and accordingly, the organic light emitting element **300** displays an image by emitting light to at least one direction of the first substrate **100** and the flexible protection layer **500**.

The capacitor **80** includes a pair of capacitor plates **158** and **178** arranged interposing an interlayer insulating layer **161** therebetween. The interlayer insulating layer **161** may be a dielectric material, and capacitance of the capacitor **80** is determined by charges charged in the capacitor **80** and a voltage between the two capacitor plates **158** and **178**.

The switching thin film transistor **11** includes a switching semiconductor layer **131**, a switching gate electrode **152**, a switching source electrode **173**, and a switching drain electrode **174**. The driving thin film transistor **21** includes a driving semiconductor layer **132**, a driving gate electrode **155**, a driving source electrode **176**, and a driving drain electrode **177**.

The switching thin film transistor **11** is used as a switch to select a pixel for light emission. The switching gate electrode **152** is connected to the gate line **151**. The switching source electrode **173** is connected to the data line **171**. The switching drain electrode **174** is distanced from the switching source electrode **173** and is connected with the capacitor plate **158** of the two capacitor plates **158** and **178**.

The driving thin film transistor **21** applies driving power to the second electrode **730** for light emission of an organic emission layer **720** of an organic light emitting diode **300** of the selected pixel. The driving gate electrode **155** is connected with the capacitor plate **158** that is connected with the switching drain electrode **174**. The driving source electrode **176** and the other capacitor plate **178** are respectively connected with the common power line **172**. The driving drain electrode **177** is disposed at the same layer where the first electrode **710** is disposed, and is connected with the first electrode **710**.

In one embodiment of the OLED display, the driving drain electrode **177** and the first electrode **710** are disposed on the same layer, but a driving drain electrode and a first electrode of other embodiments of the OLED display may be disposed in different layers and may access the first electrode through an opening formed in an insulating layer.

With such a structure, the switching thin film transistor **11** is driven by a gate voltage applied to the gate line **151** to transmit a data voltage applied to the data line **171** to the driving thin film transistor **21**. A voltage corresponding to a difference between a common voltage applied to the driving thin film transistor **21** from the common power line **172** and the data voltage transmitted from the switching thin film transistor **11** is stored in the capacitor **80**, and a current corresponding to the voltage stored in the capacitor **80** flows to the organic light emitting element **300** through the driving thin film transistor **21** such that the organic light emitting element **300** emits light.

Referring to FIG. 7, the thin film encapsulation layer **400** and the flexible protection layer **500** are sequentially formed on the organic light emitting element **300**.

The flexible protection layer **500** has a thickness in a range between about 1  $\mu\text{m}$  to about 100  $\mu\text{m}$ . In some embodiments, the flexible protection layer **500** may have a thickness of about 10  $\mu\text{m}$ . The flexible protection layer **500** is formed by embodiments of the manufacturing method of the OLED display, and thus the flexible protection layer **500** is disposed on the thin film encapsulation layer **400** by maintaining flatness even though it has a thickness of about 10  $\mu\text{m}$ .

As described, an embodiment of the OLED display is manufactured by using the embodiment of manufacturing method of the OLED display described above so that it can be large-sized with a slim thickness.

Hereinafter, another embodiment of a manufacturing method of an OLED display will be described with reference to FIG. 10 to FIG. 12.

Only characteristic portions that are different from the embodiments above are described

FIG. 10 is a flowchart of an embodiment of a manufacturing method of an OLED display. FIG. 11 and FIG. 12 illustrate an embodiment of the manufacturing method of the OLED display.

As shown in FIG. 10 and FIG. 11, a first substrate **100** is formed on a mother board **10** (S210).

The mother board **10** is rigid and includes at least one of an inorganic material such as glass, resin, or metal. The first substrate **100** formed on the mother board **10** may be a polymer film, which is flexible and includes resin. By being flexible, the first substrate **100** may be moved due to external interference or stress, but the first substrate **100** maintains a fixed state because it is formed on the rigid mother board **10**.

An organic light emitting element **300** is formed on the first substrate **100** (S220).

A wire portion **200** and an organic light emitting element **300** are formed on the first substrate **100** including flexible resin.

A thin film encapsulation layer **400** is formed on the organic light emitting element **300** (S230).

A flexible protection layer **500** is formed on the second substrate **20** (S240).

Next, the first substrate **100** and the second substrate **20** are sealed to each other (S250).

As the first substrate **100** and the second substrate **20** are sealed to each other, the flexible protection layer **500** and the thin film encapsulation layer **400** are arranged opposite to each other. The attaching between the first substrate **100** and the second substrate **20** may be performed by forming an adhesive layer on at least one of a surface of the thin film encapsulation layer **400** and a surface of a second barrier layer **BL2**.

The flexible protection layer **500** is attached on the thin film encapsulation layer **400** together with the second substrate **20** while the first substrate **100** and the flexible protection layer

**500** are being respectively fixed to the rigid mother board **10** and the rigid second substrate **20**, and accordingly, the flexible protection layer **500** can be easily attached to the thin film encapsulation layer **400** without having a difficulty in handling of the flexible protection layer **500** due to movement of each of the first substrate **100** and the flexible protection layer **500**.

As shown in FIG. 12, the second substrate **20** is separated from the flexible protection layer **500** (S260).

Then, the mother board **10** is separated from the first substrate **100** (S270).

The mother board **10** and the second substrate **20** separated through the above-stated process can be recycled in the next process.

An OLED display is manufactured by cutting the first substrate **100**, the first barrier layer **BL1**, the thin film encapsulation layer **400**, the second barrier layer **BL2**, and the flexible protection layer **500** along an imaginary cutting line **CL** disposed between neighboring organic light emitting elements **300** among the plurality of organic light emitting elements **300** using a cutting means such as laser or a diamond cutter.

According to an embodiment of the manufacturing method of the OLED display, the flexible protection layer **500** is attached on the thin film encapsulation layer **400** together with the second substrate while the first substrate **100** and the flexible protection layer **500** are being respectively fixed to the rigid mother board **10** and the rigid second substrate **20**, and accordingly, the flexible protection layer **500** can be easily attached to the thin film encapsulation layer **400** without having a difficulty in handling of the flexible protection layer **500** due to movement of each of the first substrate **100** and the flexible protection layer **500**. As the flexible protection layer **500** and the first substrate **100** attached to the thin film encapsulation layer **400** can be easily handled by using embodiments of the manufacturing method of the OLED display, an OLED display flexible, large in size, and slim in thickness can be easily manufactured by setting the thickness of first substrate **100** and the thickness of the flexible protection layer **500** to, for example, about 1  $\mu\text{m}$  to about 100  $\mu\text{m}$ .

While this disclosure has been described in connection with certain embodiments, it is to be understood that the invention is not limited to the disclosed embodiments, but, on the contrary, is intended to cover various modifications and equivalent arrangements included within the spirit and scope of the appended claims.

#### DESCRIPTION OF SYMBOLS

First substrate **100**, organic light emitting element **300**, thin film encapsulation layer **400**, flexible protection layer **500**.

What is claimed is:

1. A method of manufacturing an organic light emitting diode (OLED) display, the method comprising:
  - forming an organic light emitting element on a first substrate;
  - forming, on the organic light emitting element, a thin film encapsulation layer that seals the organic light emitting element with the first substrate;
  - providing a second substrate;
  - forming a flexible protection layer on the second substrate;
  - forming a sacrificial layer between the second substrate and the flexible protection layer;
  - forming a barrier layer on the flexible protection layer;
  - attaching the first substrate and the second substrate to each other by attaching the barrier layer to the thin encapsulation layer; and

separating the second substrate from the flexible protection layer by removing the sacrificial layer simultaneously from both the second substrate and the flexible protection layer.

2. The method of manufacturing of claim 1, wherein the flexible protection layer comprises resin. 5

3. The method of manufacturing of claim 1, further comprising forming the first substrate on a mother board and separating the mother board from the first substrate, wherein the first substrate comprises flexible resin. 10

4. The method of manufacturing of claim 1, wherein the thin film encapsulation layer comprises a single-layered inorganic layer.

5. The method of manufacturing of claim 1, wherein the flexible protection layer comprises at least one of a polarizing film or a phase difference film. 15

6. The method of manufacturing of claim 1, wherein the sacrificial layer comprises at least one of metal, amorphous material, silicon oxide, silicon nitride or metal oxide.

\* \* \* \* \*

专利名称(译)	有机发光二极管显示器和制造有机发光二极管显示器的方法		
公开(公告)号	<a href="#">US8987043</a>	公开(公告)日	2015-03-24
申请号	US13/300176	申请日	2011-11-18
[标]申请(专利权)人(译)	三星显示有限公司		
申请(专利权)人(译)	三星移动显示器有限公司.		
当前申请(专利权)人(译)	三星DISPLAY CO. , LTD.		
[标]发明人	PARK YONG HWAN SEO SANG JOON LEE JAE SEOB KIM SEUNG HUN KIM JIN KWANG		
发明人	PARK, YONG-HWAN SEO, SANG-JOON LEE, JAE-SEOB KIM, SEUNG-HUN KIM, JIN-KWANG		
IPC分类号	H01L51/52		
CPC分类号	H01L51/5253 H01L51/5246 H01L2227/326 H01L2251/5338		
优先权	1020110052904 2011-06-01 KR		
其他公开文献	US20120305981A1		
外部链接	<a href="#">Espacenet</a> <a href="#">USPTO</a>		

摘要(译)

一种制造OLED显示器的方法，包括：在第一基板上形成有机发光元件；在有机发光元件上形成薄膜封装层，该薄膜封装层用第一基板密封有机发光元件；提供第二基板；在第二基板上形成柔性保护层；将第一基板和第二基板彼此连接；将第二基板与柔性保护层分离。

